

foodproof[®]

StarPrep Six 8-Strip Kit

High-Throughput

PRODUCT INSTRUCTIONS

Documentation for the high-throughput extraction of DNA from yeast & mold for direct use in PCR

Product No. KIT230192

foodproof[®]
StarPrep Six 8-Strip Kit
High-Throughput

Product No.: KIT230192
Kit for 192 reactions

Store kit at 15 to 25 °C
FOR *IN VITRO* USE ONLY

Product Instructions:
Revision A, January 2024

TABLE OF CONTENTS

1. OVERVIEW 4

1.1 General Information..... 4

1.2 Applicability 4

1.3 Kit Contents..... 5

2. INSTRUCTIONS 6

2.1 Required Material 6

2.2 Precautions and Preparations 9

2.3 VIAFLO 96 Program 10

2.4. Workflows..... 13

 2.4.1 Extraction Procedure A: Standard..... 14

 2.4.2. Extraction Procedure B: Viaflo 96 19

2.5 Troubleshooting..... 24

2.6 Support..... 25

3. ADDITIONAL INFORMATION 26

3.1 General Information..... 26

3.2 Reference Number 27

3.3 Change Index 27

OVERVIEW

1. OVERVIEW

The foodproof® StarPrep Six 8-Strip Kit is designed for the rapid preparation of DNA from yeast & mold for direct use in PCR. This protocol includes a differentiation step of live and dead cells with Reagent D. Up to 96 samples can be processed in parallel. In less than 3 hours (without sample weigh-in and dilution), the kit generates PCR template DNA from up to 1,000 µL of sample. The obtained DNA can be used directly in any PCR application. The special lysis buffer eliminates the need for hazardous organic extractions or chaotropic agents. The reduced number of handling steps results in time savings and the cross-contamination risks are minimized.

1.1 General Information

Number of Reactions

The kit is designed for 192 reactions.

Storage Conditions

Store at 15 to 25 °C.

The components of the foodproof StarPrep Six 8-Strip Kit are guaranteed to be stable through the expiration date printed on the label.

1.2 Applicability

The lysis buffer can be used to prepare DNA from up to 1,000 µL sample and is optimized for the preparation of various types of sample material. The quality of the DNA obtained with the lysis buffer is suitable for any PCR application.

OVERVIEW**1.3 Kit Contents**

A schematic representation of the foodproof StarPrep Six 8-Strip Kit with all components:

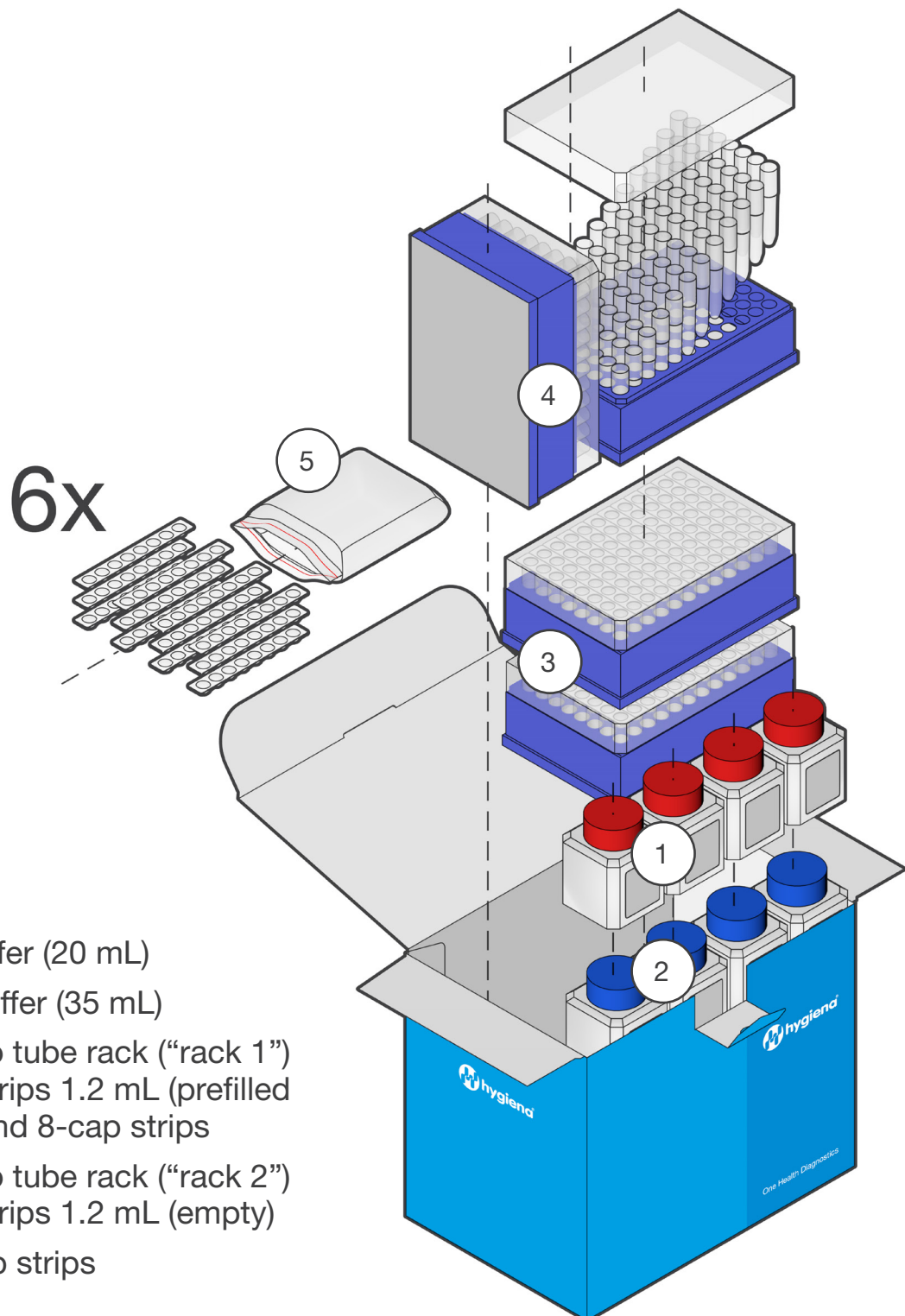

1. 4x lysis buffer (20 mL)
2. 4x wash buffer (35 mL)
3. 2x 96 micro tube rack ("rack 1") with 8-tube strips 1.2 mL (prefilled with beads) and 8-cap strips
4. 2x 96 micro tube rack ("rack 2") with 8-tube strips 1.2 mL (empty)
5. 6x 12 8-cap strips

INSTRUCTIONS

2. INSTRUCTIONS

This section provides all information for a straightforward DNA extraction from a variety of different food matrices.

2.1 Required Material

Most of the required equipment and reagents are available through Hygiena®.

Please contact us for further information.



It is highly recommended to only use the materials described below to guarantee the robustness of the method.

Reagents

Reagent D

Product No. KIT230001

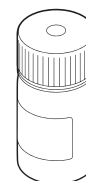

Sterile **sodium citrate** (Trisodium 2-hydroxypropane-1,2,3-tricarboxylate; CAS Number: 6132-04-3) **solution** 2% (w/v)

Not provided by Hygiena® Diagnostics

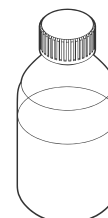

Consumables

Sterile **reservoir**

25 mL or 100 mL

Only for procedure A: Standard (2.4.1)

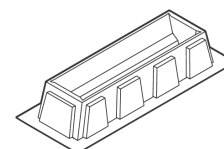

Automation friendly reservoirs

Sterile 150 mL, reservoir base and lid - INTEGRA Biosciences

Only for procedure B: Viaflo 96 (2.4.2)

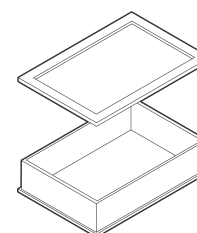

INSTRUCTIONS

Equipment

Multichannel pipette and filter tips

e.g., 8-Channel Pipette VIAFLO - INTEGRA Biosciences
with GripTips: 50 to 1,250 μ L

or EP Xplorer Plus Electronic Multichannel Pipette
with Filter Tips: 50 to 1,250 μ L

Only for procedure A: Standard (2.4.1)



Benchtop pipetting system and deep well tips

VIAFLO 96 base unit,
96 channel pipetting head, 50-1250 μ L,
Spring-loaded plate holder A & B for 96 well plates

- all from INTEGRA Biosciences;

GripTips in racks: 50 to 1,250 μ L

Only for procedure B: Viaflo 96 (2.4.2)

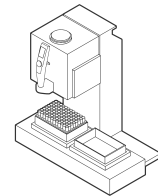

Lab **homogenizer** / blender

e.g., BagMixer 400 W - Interscience

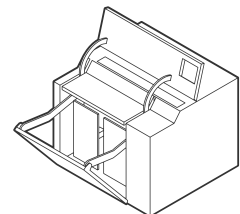

Unit for mechanical cell disruption suitable for working with
1.2 mL x 8-tube strips

Mixer Mill 400 Retsch GmbH

with rack adapter TissueLyser Adapter Set 2x96 Qiagen

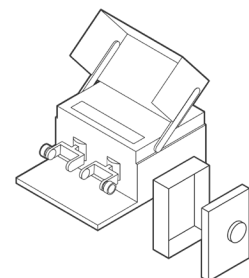

Centrifuge with swing-out rotor for microtiter plates capable
of a $> 5,400 \times g$ centrifugal force

e.g., Sigma 4-16S including rotor

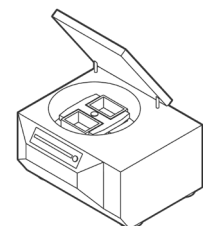

INSTRUCTIONS



TH 21 heating block thermostat

Exchange block for deepwell plates for TH 21

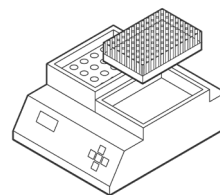

Lid weight with **incubation frame** for TH 21 heating block thermostat

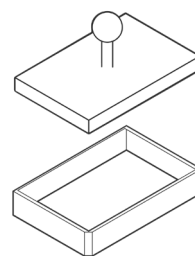

D-Light

Product No. MCH230039

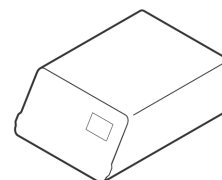

Decapper 8-strip

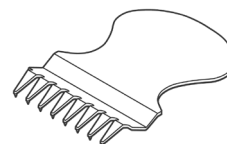

Recommended:

Cap installing tool

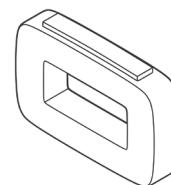

INSTRUCTIONS

2.2 Precautions and Preparations

Follow all universal safety precautions governing work with biohazardous materials, e.g., wear lab coats and gloves at all times. Properly dispose of all contaminated materials, decontaminate work surfaces, and use a biosafety cabinet whenever aerosols might be generated.

For more information, please refer to the appropriate safety data sheet (SDS). The SDS is available online at www.hygiena.com/sds.

- Always use filter tips in order to avoid cross-contamination.

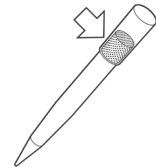

- To reach the required temperature of 95 to 100 °C in the tubes for the lysis step of the bacteria, the temperature of the corresponding **heating unit TH 21 has to be set to 100 °C**.

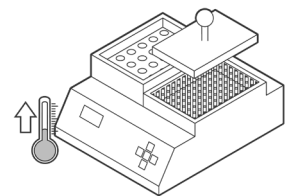

- Thaw the Reagent D prior to use.
Avoid more than three freeze-thaw cycles. If necessary, aliquots can be prepared and stored according to the Reagent D product instructions. Avoid extended exposure to light.

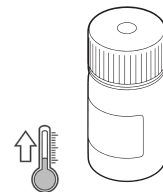

INSTRUCTIONS

2.3 VIAFLO 96 Program

The VIAFLO 96 is a pipetting system, which enables the transfer of 96 samples in a single step. The following table shows how to program the instrument for the extraction procedure B: Viaflo 96 (2.4.2.)

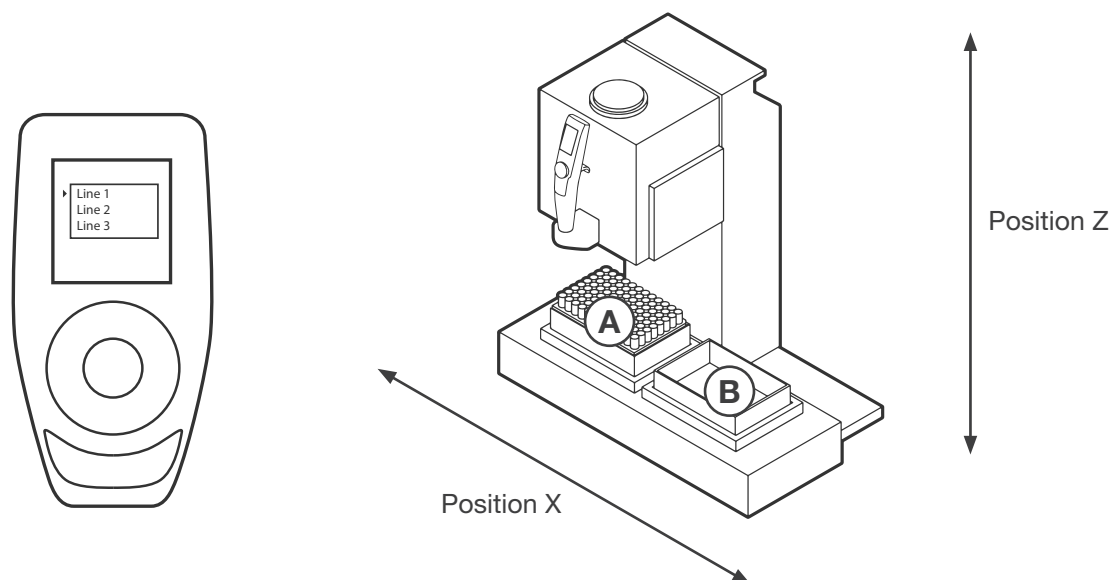

Step	Action	PositionX	PositionZ	Line1	Line2	Line3	Volume	Speed	Cycles
1	Move (X,Z)	79,5	192,5						
2	Prompt			POSITION B	ADD	TIP BOX			
3	Prompt			POSITION A	ADD	RACK 1			
4	Tip Change								
5	Move (X,Z)	-80	90						
6	Aspirate						500	1	
7	Move (X,Z)	-80	76						
8	Aspirate						400	1	
9	Move (X,Z)	79,5	192,5						
10	Move (X,Z)	79,5	90						
11	Purge							5	
12	Prompt			POSITION A	REMOVE	RACK 1			
13	Prompt			NEXT	EXTERNAL	STEP 8*			

Note: *Continue with respective step of the extraction procedure B: Viaflo 96

INSTRUCTIONS

Step	Action	PositionX	PositionZ	Line1	Line2	Line3	Volume	Speed	Cycles
14	TipChange								
15	Move (X,Z)	-79,5	192,5						
16	Prompt			POSITION A	ADD	RESERVOIR 1			
17	Move (X,Z)	-80	72,5						
18	Aspirate						300	1	
19	Move (X,Z)	79,5	192,5						
20	Prompt			POSITION A	REMOVE	RESERVOIR 1			
21	Prompt			POSITION A	ADD	RACK 1			
22	Move (X,Z)	-80	80						
23	Dispense						300	10	
24	Move (X,Z)	-80	80						
25	Mix						300	10	10
26	Move (X,Z)	79,5	192,5						
27	Move (X,Z)	79,5	90						
28	Prompt			POSITION A	REMOVE	RACK 1			
29	Prompt			NEXT	EXTERNAL	STEP 10*			
30	TipChange								
31	Move (X,Z)	-79,5	192,5						
32	Prompt			POSITION A	ADD	RESERVOIR 2			
33	Move (X,Z)	-80	73						
34	Aspirate						600	10	
35	Move (X,Z)	79,5	192,5						
36	Prompt			POSITION A	REMOVE	RESERVOIR 2			
37	Prompt			POSITION A	ADD	RACK 2			
38	Move (X,Z)	-80	110						
39	Dispense						600	10	
40	Move (X,Z)	79,5	192,5						

Note: *Continue with respective step of the extraction procedure B: Viaflo 96
RACK = tube rack

INSTRUCTIONS

Step	Action	PositionX	PositionZ	Line1	Line2	Line3	Volume	Speed	Cycles
41	Prompt			POSITION A	REMOVE	RACK 2			
42	Prompt			POSITION A	ADD	RACK 1			
43	Prompt			REMOVE	RACK LID	RACK 1			
44	Move (X,Z)	-80	73						
45	Mix						350	10	10
46	Aspirate						400	10	
47	Move (X,Z)	79,5	192,5						
48	Prompt			POSITION A	REMOVE	RACK 1			
49	Prompt			POSITION A	ADD	RACK 2			
50	Move (X,Z)	-80	110						
51	Dispense						400	10	
52	Move (X,Z)	-80	90						
53	Mix						400	10	5
54	Move (X,Z)	79,5	192,5						
55	Prompt			POSITION A	REMOVE	RACK 2			
56	Prompt			POSITION A	ADD	STEP 14*			
57	Prompt			POSITION A	ADD	RACK 2			
58	Move (X,Z)	-80	90						
59	Aspirate						500	1	
60	Move (X,Z)	-80	80						
61	Aspirate						400	1	
62	Move (X,Z)	79,5	192,5						
63	Move (X,Z)	79,5	90						
64	Purge							5	
65	Prompt			POSITION A	REMOVE	RACK 2			
66	Prompt			NEXT	EXTERNAL	Step 18*			

Note: *Continue with respective step of the extraction procedure B: Viaflo 96

INSTRUCTIONS

Step	Action	PositionX	PositionZ	Line1	Line2	Line3	Volume	Speed	Cycles
67	TipChange								
68	Move (X,Z)	79,5	192,5						
69	Prompt			POSITION A	ADD	RESERVOIR 3			
70	Move (X,Z)	-80	73						
71	Mix						300	10	10
72	Aspirate						300	10	
73	Move (X,Z)	79,5	192,5						
74	Prompt			POSITION A	REMOVE	RESERVOIR 3			
75	Prompt			POSITION A	ADD	RACK 2			
76	Move (X,Z)	-80	110						
77	Dispense						300	10	
78	Move (X,Z)	-80	80						
79	Mix						300	10	10
80	Move (X,Z)	79,5	192,5						
81	Move (X,Z)	79,5	90						
82	Purge							5	
83	Prompt			POSITION A	REMOVE	RACK 2			
84	Prompt			NEXT	EXTERNAL	STEP 20*			
85	Prompt			VIAFLO 96	PROTOCOL	FINISHED			
86	Prompt			QUIT AND	REMOVE	TIPS			

Note: *Continue with respective step of the extraction procedure B: Viaflo 96

2.4. Workflows

Procedure A: Standard describes the DNA extraction from up to 1,000 µL enrichment culture using 8-strip tubes and multichannel pipettes.

The Viaflo 96 protocol (B) includes the VIAFLO 96 as a pipetting device, which enables the transfer of 96 samples in a single step.

2.4.1 EXTRACTION PROCEDURE A: STANDARD

2.4.1 EXTRACTION PROCEDURE A: STANDARD

The following protocol describes the DNA isolation using 8-tube strips and multichannel pipettes.

A step for live and dead cell differentiation with Reagent D is included.

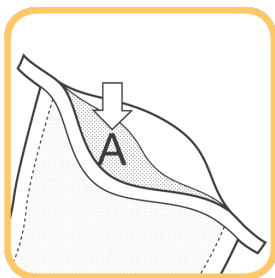

1. RESUSPEND SAMPLE

Dilute sample with **buffer solution 1:10 (w/v) with sodium citrate solution 2% (w/v)** in a suitable blender bag with filter layer.

Note: Weigh the sample in one side (A) of the blender bag with filter layer.



2. HOMOGENIZE SAMPLE

Homogenize for **60 s at maximum speed** in a homogenization unit.

Let the suspension settle for 5 to 10 min.

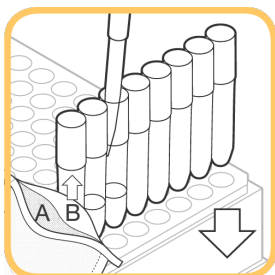

3. ADD SAMPLE (RACK 1)

Transfer **1,000 µL sample suspension** (supernatant) to the empty 8-tube strips (**without beads**) of rack 1.

Note: Use the supernatant from the other side (B) of the blender bag.

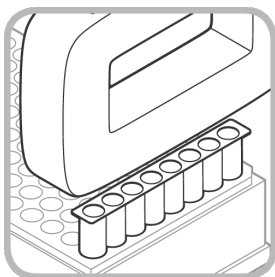

4. SEAL TUBES

Seal the tubes with sterile cap strips.

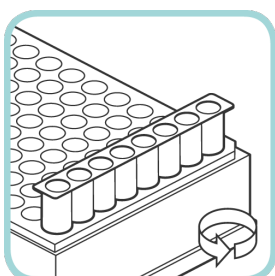

5. CENTRIFUGE RACK 1

10 min at 5,400 x g.

Make sure the **rack is not sealed** with rack lid during centrifugation.

Note: Set the centrifuge acceleration to maximum speed and the brake to medium (e.g., 9/3). If necessary, centrifugation forces should be calculated according to the manual of the used centrifuge.

2.4.1 EXTRACTION PROCEDURE A: STANDARD

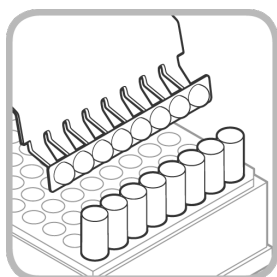

6. REMOVE CAPS

Remove and discard the 8-cap strips from the 8-tube strips.
To minimize the contamination risk, use the decapper 8-strip tool.

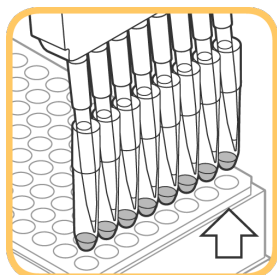

7. REMOVE SUPERNATANT

Remove **only 900 µL supernatant** carefully with a multichannel pipette immediately after centrifugation, discard and inactivate appropriately.

Note: Take care that the tips of the pipette in the reaction tubes are not touching the pellets.

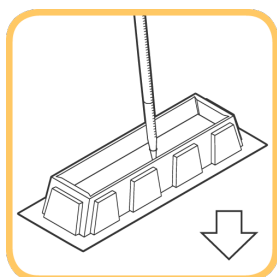

8. PREPARE REAGENT D

Transfer an adequate volume of **Reagent D** in a sterile reservoir:
300 µL per sample and **1 mL** as dead volume.

Note: The lights in the clean bench must be switched off. Proceed immediately with the following steps of the protocol. Avoid extended exposure to light.

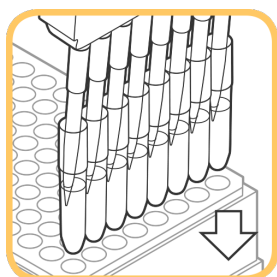

9. ADD REAGENT D AND MIX

Transfer **300 µL Reagent D** with a multichannel pipette to each tube.
Resuspend pellets by pipetting up and down 5 to 10 times.

Note: For optimal DNA isolation efficiency, pellet has to be completely resuspended. For uptake of Reagent D and mix, pipet with maximum speed of the automatic pipette. Proceed immediately with the following steps of the protocol. Avoid extended exposure to light.

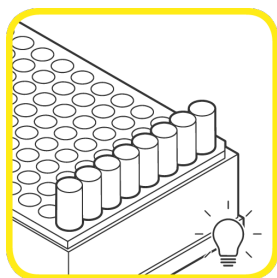

10. D-LIGHT TREATMENT

Do not seal the 8-tube strips with 8-cap strips.

Close the 8-tube strips of rack 1 with the **transparent rack lid only** and place it in the D-Light unit.

Incubate first **in the dark for 10 min** and subsequently **expose to light for 5 min** at room temperature in the D-Light unit.

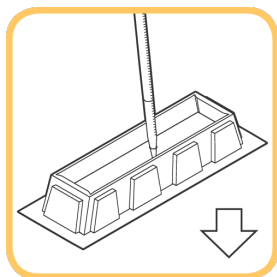

11. PREPARE WASH BUFFER

Transfer an adequate volume of **wash buffer** in a sterile reservoir:
600 µL per sample and **1 mL** as dead volume.

2.4.1 EXTRACTION PROCEDURE A: STANDARD

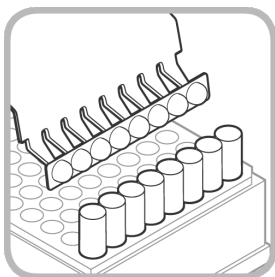

12. REMOVE CAPS (RACK 2)

Remove and discard the 8-cap strips from a **new 8-tube strip with beads** (rack 2). To minimize the contamination risk, use the decapper 8-strip tool.

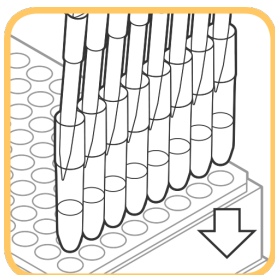

13. ADD WASH BUFFER

Transfer **600 µL wash buffer** with a multichannel pipette to the tubes of rack 2.

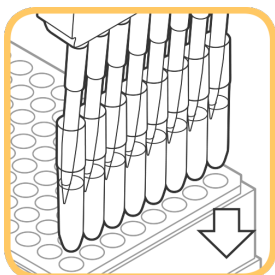

14. ADD VOLUMES OF RACK 1 TO RACK 2

Resuspend samples in rack 1 ten times.

Transfer the **whole volume** (~ 400 µL) from the 8-tube strips of rack 1 (from step 10) with a multichannel pipette to the 8-tube strips with beads and wash buffer of rack 2. Mix 5 times.

Note: For uptake and mix pipet with maximum speed of the automatic pipette.

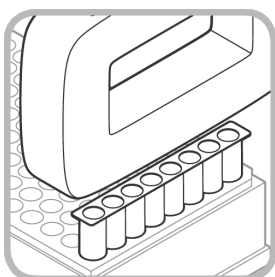

15. SEAL TUBES

Seal the tubes with sterile cap strips.

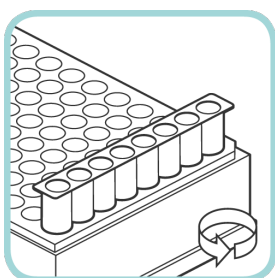

16. CENTRIFUGE RACK 1

10 min at 5,400 x g.

Make sure the **rack is not sealed** with rack lid during centrifugation.

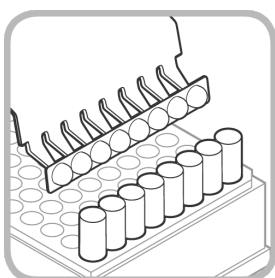

17. REMOVE CAPS

Remove and discard the 8-cap strips from the 8-tube strips. To minimize the contamination risk, use the decapper 8-strip tool.

2.4.1 EXTRACTION PROCEDURE A: STANDARD

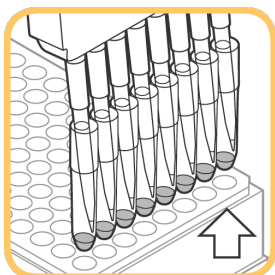

18. REMOVE SUPERNATANT

Remove **only 900 µL supernatant** carefully with a multichannel pipette immediately after centrifugation, discard and inactivate appropriately.

Note: Take care that the tips of the pipette in the reaction tubes are not touching the pellets.

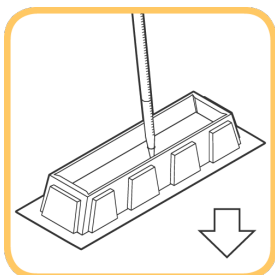

19. PREPARE LYSIS BUFFER

Transfer an adequate volume of **lysis buffer** in a sterile reservoir: **300 µL** per sample and **1 mL** as dead volume.

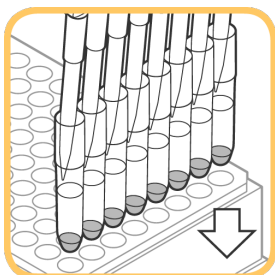

20. ADD LYSIS BUFFER

Pipet the lysis buffer 5 to 10 times up and down in the reservoir before using to avoid sedimentation of ingredients.

Transfer **300 µL lysis buffer** with a multichannel pipette to each tube. **Resuspend pellets** by pipetting up and down 5 times.

Note: For optimal DNA isolation efficiency, pellet has to be completely resuspended. For uptake of Reagent D and mix, pipet with maximum speed of the automatic pipette.

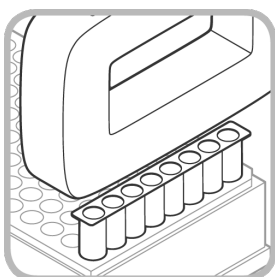

21. SEAL TUBES

Seal the tubes with sterile cap strips.

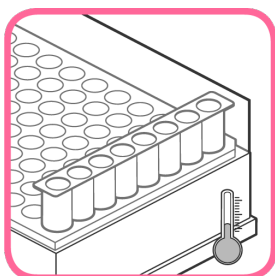

22. INCUBATE

30 min at room temperature.

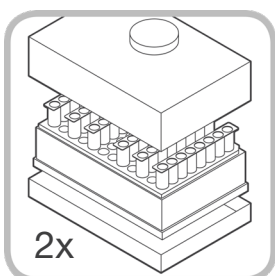

23. INSTALL ADAPTER SET

Place the rack **without rack lid** in the TissueLyser Adapter Set.

Note: Split the tube strips into 2 groups and place them into two tube racks to prepare appropriate counterweights for disruption. Place the tube strips into the racks in an even and balanced manner. Make sure each rack contains at least two strips placed in the outermost positions (row 1 and 12 of the rack). If you prepare only a few samples (less than 4 strips) it is necessary to use additional tube strips prefilled with 450 µL water to balance it out.

2.4.1 EXTRACTION PROCEDURE A: STANDARD

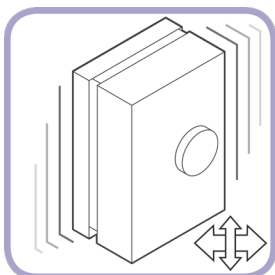

24. MECHANICAL DISRUPTION

Place the 2 adapters in the cell disruption unit and run mechanical disruption **Mixer Mill 400: 15 min at 30 Hz.**

The efficiency of disruption depends on the mechanical cell disruption unit.

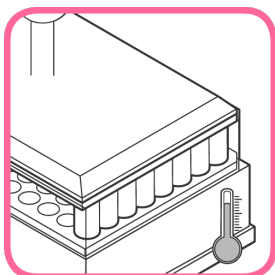

25. INCUBATE

Remove tube rack bottom and install incubation frame.

Incubate rack with tube strips **30 min at 100 °C** in the TH 21 Heating Block for 8-tube strips.

Weight caps down with the lid weight.

Note: To avoid removing and reinstalling the bottom, it is possible to place tube strips in an empty micro tube rack (with rack bottom removed).

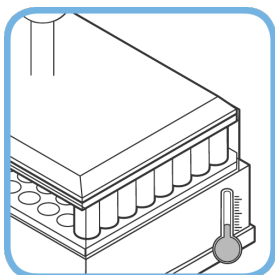

26. CHILL

Carefully **remove** the rack with the **tube strips together with the lid weight** from the heating unit and let it **cool 3 - 5 min at room temperature.**

To avoid opening of caps, do not remove the lid weight until the strips have cooled down.

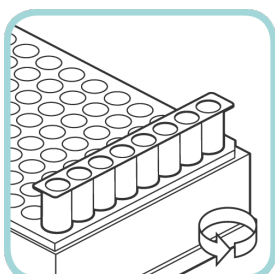

27. CENTRIFUGE RACK

Reinstall tube rack bottom.

Centrifuge **15 min at 5,400 x g.**

Make sure the rack is not sealed with rack lid during centrifugation.

Note: Time and g-force depend on the centrifuge (please see 2.1. Required Material for more information). Set the centrifuge acceleration to maximum speed and the brake to medium. If necessary, centrifugation forces should be calculated according to the manual for the centrifuge used.

SUPERNATANT FOR DETECTION

Use up to 25 µL supernatant in combination with foodproof PCR Kits.

Note: Strictly avoid transferring fractions of the sediment to the PCR reaction as this might cause PCR inhibition.

For later analysis, store DNA at -15 to -25 °C.

After thawing, mix briefly by vortexing and centrifuge at 5,400 x g for 15 min.

Note: The sample is not purified. Proteins, RNA, and other materials remain in the sample. Long-term storage or archival of prepared DNA samples is not recommended.

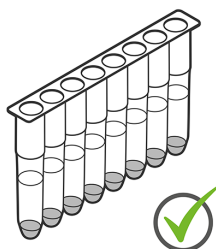

2.4.2 EXTRACTION PROCEDURE B: VIAFLO 96

2.4.2. EXTRACTION PROCEDURE B: VIAFLO 96

The following protocol describes the DNA extraction from 1,000 µL sample using the VIAFLO 96 instrument. This procedure is equivalent to Procedure A: Standard (2.4.1.).

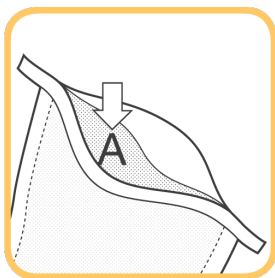

1. RESUSPEND SAMPLE

Dilute sample with **buffer solution 1:10 (w/v) with sodium citrate solution 2% (w/v)** in a suitable blender bag with filter layer.

Note: Weigh the sample in one side (A) of the blender bag with filter layer.



2. HOMOGENIZE SAMPLE

Homogenize for **60 s at maximum speed** in a homogenization unit. Let the suspension settle for 5 to 10 min.

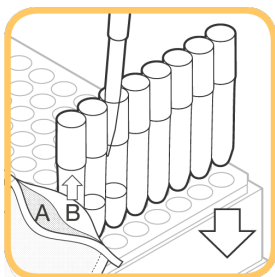

3. ADD SAMPLE (RACK 1)

Transfer **1,000 µL sample suspension** (supernatant) to the empty 8-tube strips (**without beads**) of rack 1.

Note: Use the supernatant from the other side (B) of the blender bag.

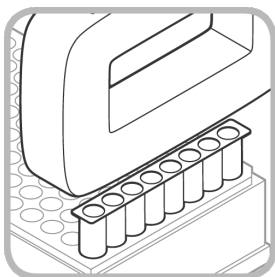

4. SEAL TUBES

Seal the tubes with sterile cap strips.

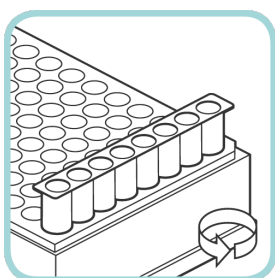

5. CENTRIFUGE RACK 1

10 min at 5,400 x g.

Make sure the **rack is not sealed** with rack lid during centrifugation.

Note: Set the centrifuge acceleration to maximum speed and the brake to medium (e.g. 9/3). If necessary, centrifugation forces should be calculated according to the manual for the centrifuge used.

2.4.2 EXTRACTION PROCEDURE B: VIAFLO 96

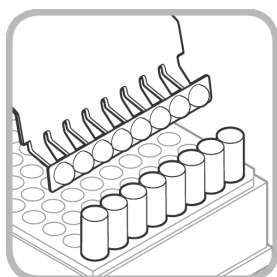

6. REMOVE CAPS

Remove and discard the 8-cap strips from the 8-tube strips. To minimize the contamination risk, use the decapper 8-strip tool.

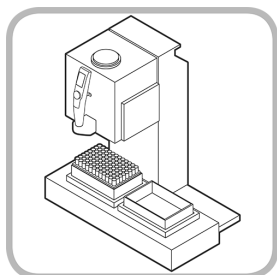

7. START VIAFLO96 PROGRAM

Switch on the VIAFLO96 instrument. Start program “YM STARPREPSIX” and follow the instructions. Run protocol step 1 to step 13.

Note: Step 'Tip Change' means to discard any used tips, to remove the waste box from position B and to add a tip box at position B.

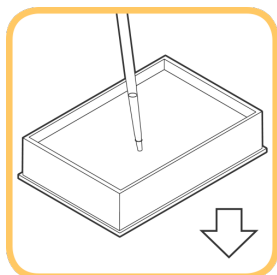

8. PREPARE REAGENT D

Transfer required Reagent D to a sterile VIAFLO 96 reservoir (reservoir 1). **300 µL** per sample plus **5 mL** as dead volume.

Note: The lights in the clean bench must be switched off. Proceed immediately with the following steps of the protocol. Avoid extended exposure to light.

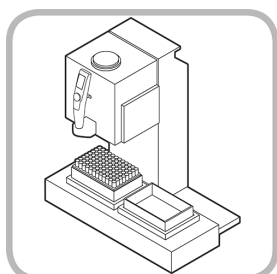

9. CONTINUE VIAFLO96 PROGRAM

Run protocol step 14 to step 29.

Note: Step 'Tip Change' means to discard any used tips, to remove the waste box from position B and to add a tip box at position B.

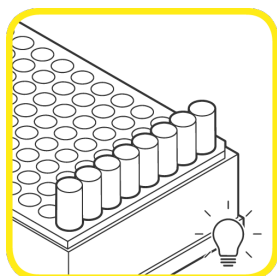

10. D-LIGHT TREATMENT

Do not seal the 8-tube strips with with 8-cap strips.

Close the 8-tube strips of rack 1 with the **transparent rack lid only** and place it in the D-Light unit.

Incubate first **in the dark for 10 min** and subsequently **expose to light for 5 min** at room temperature in the D-Light unit.

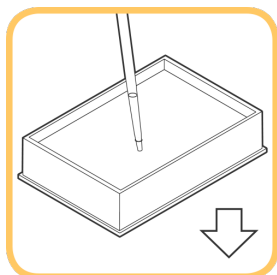

11. PREPARE WASH BUFFER

Transfer required wash buffer to a sterile VIAFLO 96 reservoir (reservoir 2). **600 µL** per sample plus **5 mL** as dead volume.

2.4.2 EXTRACTION PROCEDURE B: VIAFLO 96

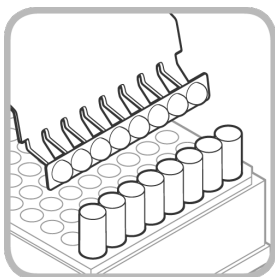

12. REMOVE CAPS (RACK 2)

Remove and discard the 8-cap strips from a **new 8-tube strip with beads** (rack 2). To minimize the contamination risk, use the decapper 8-strip tool.

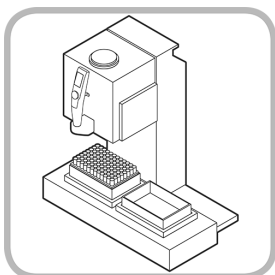

13. CONTINUE VIAFLO96 PROGRAM

Run protocol step 30 to step 56.

Note: Step 'Tip Change' means to discard any used tips, to remove the waste box from position B and to add a tip box at position B.

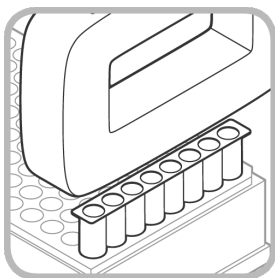

14. SEAL TUBES

Seal the tubes **tightly** with new sterile cap strips.

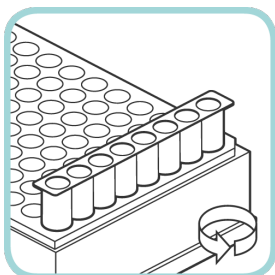

15. CENTRIFUGE RACK 2

10 min at 5,400 x g.

Make sure the **rack is not sealed** with rack lid during centrifugation.

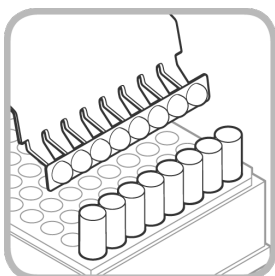

16. REMOVE CAPS

Remove and discard the 8-cap strips from the 8-tube strips. To minimize the contamination risk, use the decapper 8-strip tool.

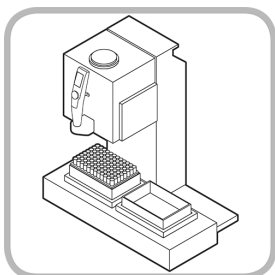

17. CONTINUE VIAFLO96 PROGRAM

Run protocol step 57 to step 66.

2.4.2 EXTRACTION PROCEDURE B: VIAFLO 96

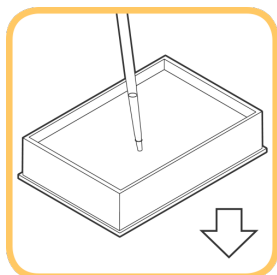

18. PREPARE LYSIS BUFFER

Transfer required lysis buffer to a sterile VIAFLO 96 reservoir (reservoir 3).
300 µL per sample plus **5 mL** as dead volume.

Note: Shake the bottle with lysis buffer gently in a short time interval to avoid sedimentation of ingredients.

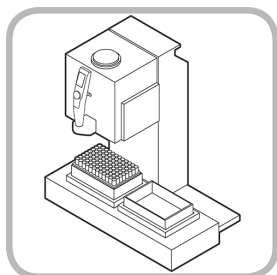

19. CONTINUE VIAFLO96 PROGRAM

Run protocol step 67 to step 84.

Note: Step 'Tip Change' means to discard any used tips, to remove the waste box from position B and to add a tip box at position B.

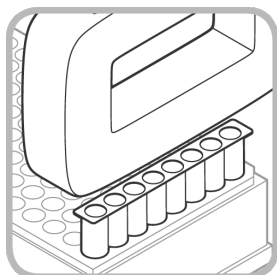

20. SEAL TUBES

Seal the tubes **tightly** with new sterile cap strips.

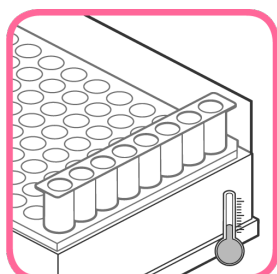

21. INCUBATE

30 min at room temperature.

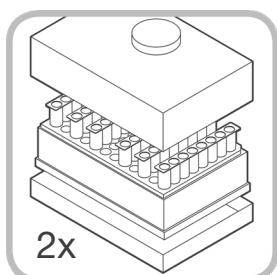

22. INSTALL ADAPTER SET

Place the rack **without rack lid** in the TissueLyser Adapter Set.

Note: Split the tube strips into 2 groups and place them into two tube racks to prepare appropriate counterweights for disruption. Place the tube strips into the racks in an even and balanced manner. Make sure each rack contains at least two strips placed in the outermost positions (row 1 and 12 of the rack). If you prepare only a few samples (less than 4 strips) it is necessary to use additional tube strips prefilled with 450 µL water to balance it out.

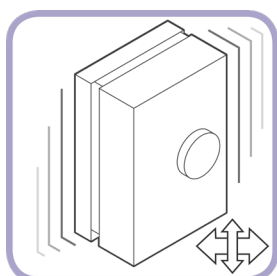

23. MECHANICAL DISRUPTION

Place the 2 adapters in the cell disruption unit and run mechanical disruption
Mixer Mill 400: 15 min at **30 Hz**.

The efficiency of disruption depends on the mechanical cell disruption unit.

2.4.2 EXTRACTION PROCEDURE B: VIAFLO 96

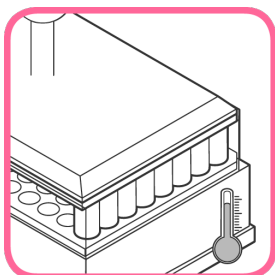

24. INCUBATE

Remove tube rack bottom and install incubation frame.

Incubate rack with tube strips **30 min at 100 °C** in the TH 21 Heating Block for 8-tube strips.

Weight caps down with the lid weight.

Note: To avoid removing and reinstalling the bottom, it is possible to place tube strips in an empty micro tube rack (with rack bottom removed).

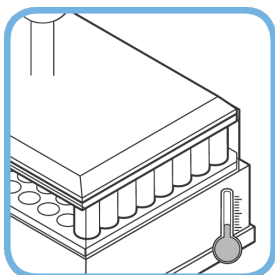

25. CHILL

Carefully **remove** the rack with the **tube strips together with the lid weight** from the heating unit and let it **cool 3 - 5 min at room temperature**.

To avoid opening of caps, do not remove the lid weight until the strips have cooled down.

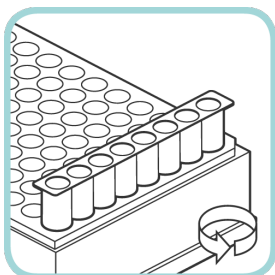

26. CENTRIFUGE RACK

Reinstall tube rack bottom.

Centrifuge **15 min at 5,400 x g**.

Make sure the rack is not sealed with rack lid during centrifugation.

Note: Time and g-force depend on the centrifuge (please see 2.1. Required Material for more information). Set the centrifuge acceleration to maximum speed and the brake to medium. If necessary, centrifugation forces should be calculated according to the manual for the centrifuge used.

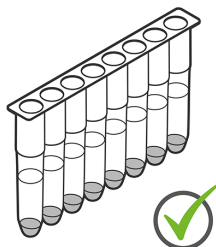

SUPERNATANT FOR DETECTION

Use up to 25 µL supernatant in combination with foodproof PCR Kits.

Note: Strictly avoid transferring fractions of the sediment to the PCR reaction because this might cause PCR inhibition.

For later analysis, store DNA at -15 to -25 °C.

After thawing, mix briefly by vortexing and centrifuge at 5,400 × g for 15 min.

Note: The sample is not purified. Proteins, RNA, and other materials remain in the sample. Long-term storage or archival of prepared DNA samples is not recommended.

TROUBLESHOOTING

2.5 Troubleshooting

Problem	Possible Cause	Recommendation
Extract inhibits PCR	Sample contains too many PCR inhibitors.	Dilute the DNA extract (1:2). Repeat DNA extraction with a reduced sample volume.
	Some of the centrifugation pellet transferred over to the PCR.	Always centrifuge the DNA sample before performing PCR. Do not allow the filter tip to have contact with the pellet.
Low DNA yield	Improper storage of kit components.	Store kit reagents at 15 to 25 °C.
	Sample contains substances that reduce the DNA extraction efficiency.	Reduce the sample volume.
	Pellet resuspension incomplete.	Improve resuspension by prolonged pipetting or vortexing.
	Suboptimal reaction conditions.	Ensure proper heating conditions. Verify correct temperature of the heating block with a thermometer.
Lid of the reaction tube opens during or after heating	Reaction tube not firmly closed or not enough weight exerted on the caps of the tube strips.	Ensure that all reaction tubes are firmly closed before heating. Weigh the caps down during heating and do not remove the weight until the tubes have cooled down.

2.6 Support

If you have questions or experience any problems with our products, please contact us:



www.hygiena.com/support

Our aim is to provide you with a solution as quickly and effectively as possible. We would also like you to contact us if you have any suggestions for improving the product or in case you would like to use our product for a different application. We highly value your feedback.

ADDITIONAL INFORMATION

3. ADDITIONAL INFORMATION

3.1 General Information

Quality Control

All products are regularly monitored by our quality control. You can find the certificate of analysis (COA) on our website. If you would like to carry out your own quality control, you will find the analysis method described in the certificate.

Waste Disposal

All contaminated and potentially infectious material, like enrichment cultures or food samples, should be autoclaved before disposal and eliminated according to local rules and regulations. For proper disposal of unused chemicals, please refer to the SDS.

Warranty and Disclaimer of Liability

“Limited Warranty” and “Disclaimer of Liability”: Hygiena Diagnostics GmbH warrants that this product is free from defects in materials and workmanship through the expiration date printed on the label and only if the following are complied with:

- (1) The product is used according to the guidelines and instructions set forth in the product literature;
- (2) Hygiena Diagnostics GmbH does not warrant its product against any and all defects when: the defect is as a result of material or workmanship not provided by Hygiena Diagnostics GmbH; defects caused by misuse or use contrary to the instructions supplied, or improper storage or handling of the product;
- (3) All warranties of merchantability and fitness for a particular purpose, written, oral, expressed or implied, shall extend only for a period of one year from the date of manufacture. There are no other warranties that extend beyond those described on the face of this warranty;
- (4) Hygiena Diagnostics GmbH does not undertake responsibility to any purchaser of its product for any undertaking, representation or warranty made by any dealers or distributors selling its products beyond those herein expressly expressed unless expressed in writing by an officer of Hygiena Diagnostics GmbH;
- (5) Hygiena Diagnostics GmbH does not assume responsibility for incidental or consequential damages, including, but not limited to responsibility for loss of use of this product, removal or replacement labor, loss of time, inconvenience, expense for telephone calls, shipping expenses, loss or damage to property or loss of revenue, personal injuries or wrongful death;
- (6) Hygiena Diagnostics GmbH reserves the right to replace or allow credit for any modules returned under this warranty.

ADDITIONAL INFORMATION

foodproof®, microproof®, vetproof®, ShortPrep®, StarPrep®, RoboPrep® and LyoKit® are registered trademarks of Hygiena Diagnostics GmbH.

Hygiena® is a registered trademark of Hygiena.

Other brand or product names are trademarks of their respective holders.

3.2 Reference Number

The reference number and original Hygiena Diagnostics GmbH article number: S 400 22

3.3 Change Index

Version 3, July 2023:

Rebranding.

Version 2, August 2021:

New document layout and content.

S 400 22 20 -> INS-KIT230192-RevA

Hygiena®

Camarillo, CA 93012
USA

diagnostics.support@hygiena.com

Manufactured by

Hygiena Diagnostics GmbH

Hermannswerder 17
14473 Potsdam
Germany

www.hygiena.com